

# CSLS Control system for SDW

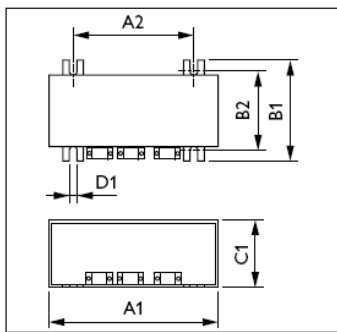

CSLS

Type	A1Nom	A2Nom	B1Nom	B2Nom	C1Nom	D1Nom
CSLS 35 SDW-T 220-240V 50/60Hz	98.0	70.0	58.5	46.0	39.5	4.5

## Electrical data

Type	Number of Lamps (x)	Rated Gear-Lamp Power	Power losses gear (W)	Line Frequency (Hz)	Line Voltage (V)	Response voltage (V)	T-case life (°C)	T-case maximum (°C)
CSLS 35 SDW-T 220-240V 50/60Hz	1	35	2.5	50/60	220-240	210	90	90
CSLS 50 SDW-T 220-240V 50/60Hz	1	50	3.0	50/60	220-240	210	90	90
CSLS 100 SDW-T 220-240V 50/60Hz	1	100	4.0	50/60	220-240	210	90	90

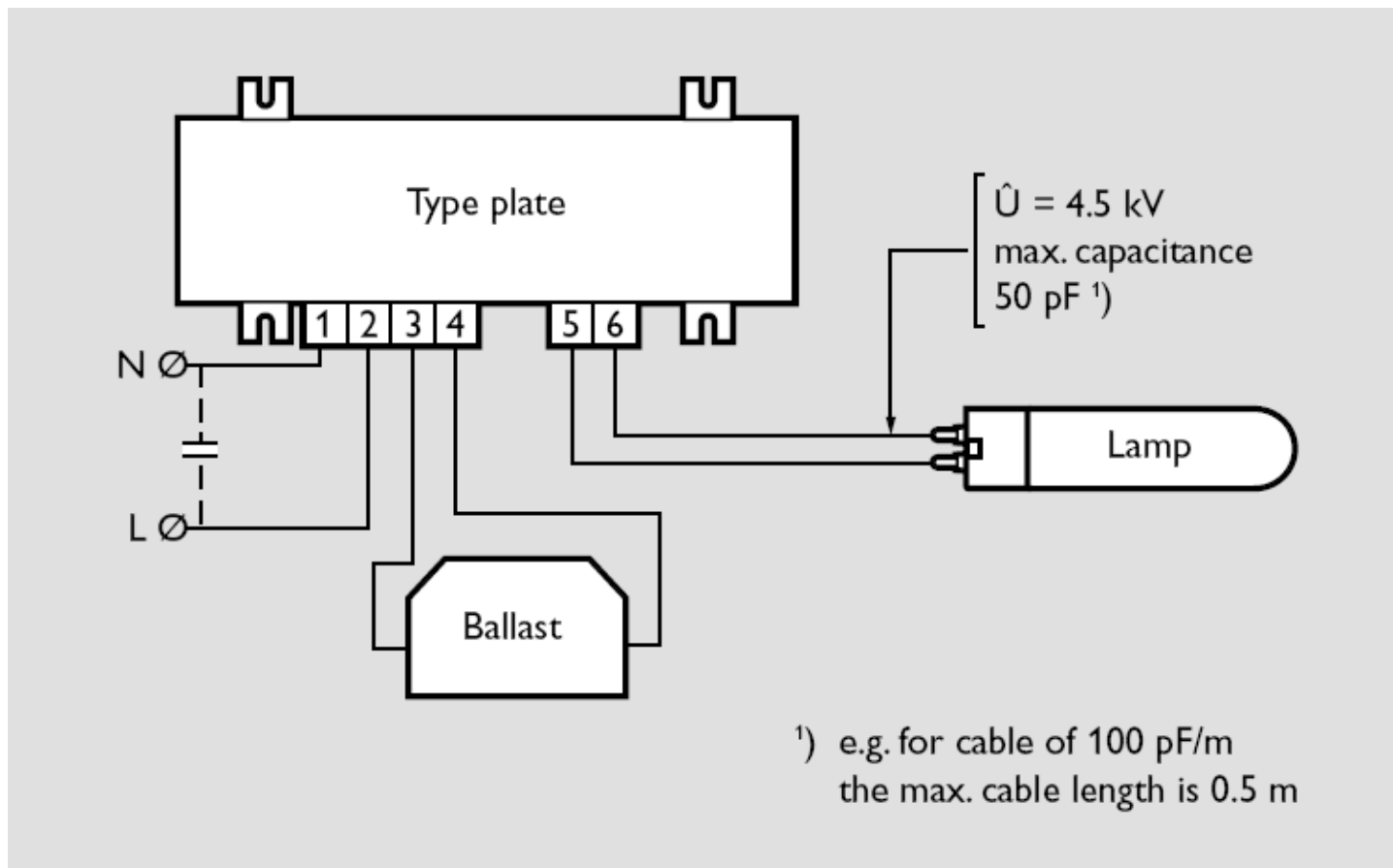

凡球照明股份有限公司

TEL: 02-8512 3888 FAX: 02-8512 3439

<http://www.circleworld.com.tw>

台北縣三重市光復路二段 80 號 9 樓之 7 Email: [john@circleworld.com.tw](mailto:john@circleworld.com.tw)